

Contact Points for COMPAC Dial Test Indicators

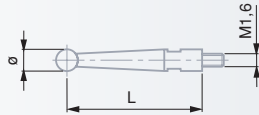

Metric Models

Carbide ball tips		Ruby ball tips						
COMPAC	TESA	COMPAC				mm	L mm	
4/210-84	01866014	÷	÷	÷		0,8	18	
4/210-82	01866003	4/210-82R		01866026		2	18	
4/210-83 210083	01866021	÷	÷	÷		3	18	
4/210L-84	01866016	÷	÷	÷		0,8	36	
4/210L-82	01866004	4/210L-82R	210L082R	01866027		2	36	
4/210L-83 210L083	01866023	÷	÷	÷		3	36	
4/240L-84 240L084	01866015	÷	÷	÷		0,8	45	
4/240L-82	01866006	4/240L-82R		01866028		2	45	
4/240L-83 240L083	01866022	÷	÷	÷		3	45	



Tungsten carbide ball tips



M1.6 coupling thread



Original inserts mounted on every indicators as well as any other inserts with same nominal length but having different tip diameters are fully interchangeable.

Inch Models

Ruby ball tips				
COMPAC	TESA	mm	L in	
4/240A-84 240A084	01866010	0,8	0.6754	
4/240A-82 240A082	01866007	2	0.6754	
4/240A-83 240A083	01866017	3	0.6754	
4/210A-84 210A084	01866011	0,8	0.72	
4/210A-82 210A082	01866005	2	0.72	
4/210A-83 210A083	01866018	3	0.72	
4/210LA-84 210LA084	01866024	0,8	1.44	
4/210LA-82	01866009	2	1.44	
4/210LA-83 210LA083	01866025	3	1.44	
4/240LA-84 240LA084	01866012	0,8	1.8	
4/240LA-82	01866008	2	1.8	
4/240LA-83 240LA083	01866019	3	1.8	

Contact points with COMPAC order codes are available while stock lasts.
Contact points with TESA order number are in stainless steel.



Accessories for COMPAC Dial Test Indicators

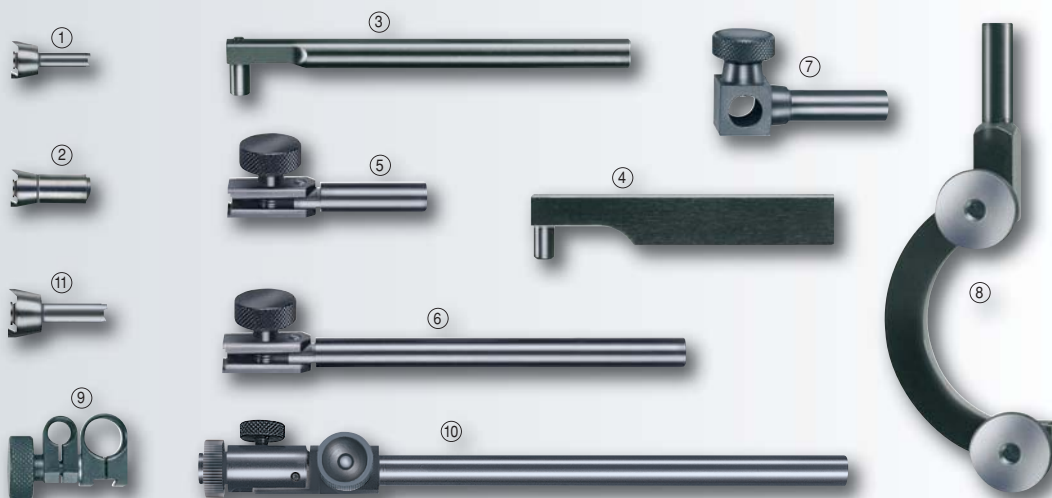

Nº	=		mm	Nº	in
01840104	①	Fixing shank with dovetail clamp	Ø 4	01850104	Ø 7/32
01840105	②	Fixing shank with dovetail clamp	Ø 8	01850105	Ø 1/4
01840202	③	Cylindrical fixing shank with tightening tenon	Ø 8 x 80 Ø 5,6	01850202	Ø 3/8 x 3.5 Ø 7/32
01840203	④	Rectangular fixing shank with tightening tenon	13 x 6 x 50 Ø 5,6	01850203	1/2 x 1/4 x 2 Ø 7/32
01840404	⑤	Short swivel holder with cylindrical shank and dovetail grip	Ø 8 x 25	01850404	Ø 3/8 x 1
01840405	⑥	Long swivel holder with cylindrical shank and dovetail grip	Ø 8 x 90	01850405	Ø 3/8 x 3.5
01840406	⑦	Angle holder with cylindrical shank Clamping bore	Ø 8 x 25 Ø 8	01850406	Ø 3/8 x 1 Ø 3/8
01840501	⑧	Centring holder for perpendicular model with cylindrical shank Clamping point for fixing shank and dovetail clamp	Ø 8 x 25 Ø 4	01840501	Ø 1/4 x 1
01860401	⑨	Double fixing clamp with clamping point and dovetail clamp	Ø 5,6	01860401	
01840407	⑩	Long swivel holder, cylindrical shank with dovetail grip. Also with fine setting.	Ø 8 x 125		
01860008	⑪	Fixing shank with dovetail clamp	Ø 6		

Nº



D

Mounting rods and lug with dovetail grip

01850106	Fixing shank swivelling through ± 30°	Ø 1/4 in
01850107	Rigid fixing shank	Ø 1/4 in
01840106	Fixing shank swivelling through ± 30°	Ø 8 mm
01840107	Rigid fixing shank	Ø 8 mm
01840108	Fixing shank swivelling through ± 30°	Ø 4 mm
01840109	Rigid fixing shank	Ø 4 mm
TA6	Rigid fixing shank	Ø 5/16 in
TMA6	Fixing shank swivelling through ± 30°	Ø 5/16 in
TA8	Rigid fixing shank	Ø 3/8 in
TMA8	Fixing shank swivelling through ± 30°	Ø 3/8 in

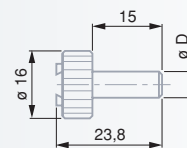
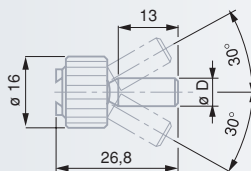

Stem



Clamping length

SPT	Rotating holder	8 mm	25 mm
SPTA	Rotating holder	1/4 in	1 in
SPTA-3/16	Rotating holder	3/16 in	1 in
SPTA-3/8	Rotating holder	3/8 in	1 in
SPTA-5/16	Rotating holder	5/16 in	1 in

