



0728 Internal precision bore gauges for large and deep bores



Model

- 2 point comparator measuring instrument with split probe + measuring pin
- Centering plate
- Mounting hole Ø 8 mm
- Ideal in conjunction with dial gauges or dial comparator gauges

Delivery

- Wooden case
- Without dial gauge

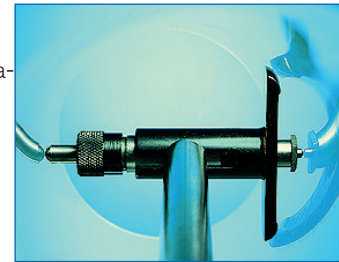

Measuring range	Repeatability	Measuring depth	Measuring pins	Measuring discs	Order no.	List price
Fixed measuring pins, hardened special steel, interchangeable contact pins are carbide tipped						
18 - 35	0.5	110	9	2	0728 105	395.00
35 - 60	0.5	138	7	2	0728 106	384.00
50 - 100	0.5	177	11	3	0728 107	439.00
100 - 160	0.5	234	7	4	0728 108	612.00
160 - 290	0.5	234	7	4	0728 109	883.00
280 - 510	1.5	400	7	4	0728 110	2084.00
Fixed measuring pins and interchangeable contact pins, both pins are carbide tipped						
4.5 - 6	0.5	80	9		0728 201	1007.00
6 - 8	0.5	100	7		0728 202	720.00
8 - 12	0.5	100	9		0728 203	671.00
12 - 20	0.5	110	9	1	0728 204	466.00
18 - 35	0.5	110	9	2	0728 205	471.00
35 - 60	0.5	138	7	2	0728 206	449.00
50 - 100	0.5	177	11	3	0728 207	525.00
100 - 160	0.5	234	7	4	0728 208	683.00
160 - 290	0.5	234	7	4	0728 209	904.00
280 - 510	1.5	400	7	4	0728 210	2133.00

0728 Setting device for internal precision bore gauges



Model

- Setting device for accurate adjustment of internal precision bore gauges to the required nominal dimension, with gauge blocks
- The setting jaws are made of carbide and are lapped to gauge block quality
- Setting device can be used in both, the vertical and horizontal measuring axis

Delivery

- Wooden case
- Incl. stand (excludes gauge blocks)

For measuring range	Error limit	Order no.	List price
4.5 - 160	2	0728 910	1245.00
18 - 290	2	0728 915	1234.00
160 - 510	2	0728 920	1786.00



0735 Crankshaft gauges

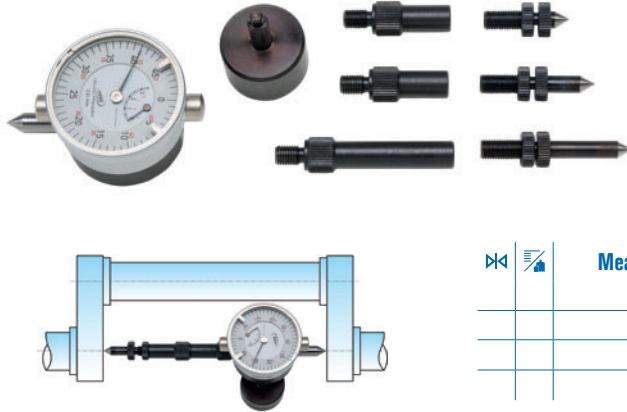

Model

- With dial gauge
- To be positioned between 2 crank arms
- Centre punch is not required
- Horizontal position of the dial gauge is assured with a plumb bob

Delivery

- Wooden case

Measuring range mm	Reading mm	Order no.	List price EUR
45 - 150	0.01	0735 101	408.00
60 - 300	0.01	0735 102	368.00
60 - 500	0.01	0735 103	427.00

0735 Replacement gauge for 0735

Model

- Without backplate

Order no.	List price EUR
For measuring range 45 - 150 mm	
0735 901	225.00
For measuring range 60 - 300 / 60 - 500 mm	
0735 902	187.00

0736 Length measuring instruments for external incisions

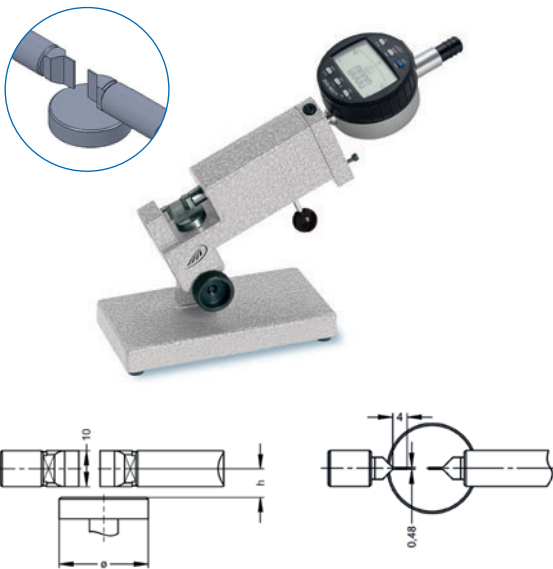

Model

- Ideal for serial measurements of incision diameters on turned parts
- Narrow measuring faces
- High precision ball guide of the transmission bolt
- Round support table, height adjustable, clamped for setting the exact measuring position
- Heavy stand
- Base unit in the angular grid 0° / 30° / 60° / 90°
- Titled and clamped
- Support for indicators with shaft Ø 8 mm
- Display devices: analogue and digital indicators

- Versions with other measuring inserts are available upon request

Delivery

- Cardboard box
- Without digital indicator (optional)

Measuring range mm	Size of table mm	Height h mm	Order no.	List price EUR
0 - 10	25	8	0736 101	942.00
0 - 25	38	13	0736 102	1016.00
25 - 50	50	35	0736 103	1088.00