

WELDING GAGE

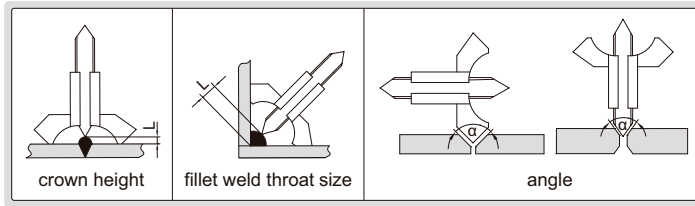

4830

Unit: mm

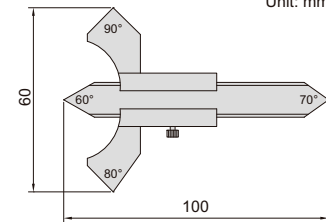

- Made of stainless steel

| Code | Measurement | Range | Graduation | Accuracy |
|------|-------------------------|--------------------|------------|----------|
| 4830 | crown height | 0-8mm | 0.1mm | ±0.1mm |
| | fillet weld throat size | 0-20mm | 0.1mm | ±0.3mm |
| | angle | 60°, 70°, 80°, 90° | — | ±1° |

ATTENTION:
NO DATA OUTPUT

DIGITAL WELDING GAGE

11

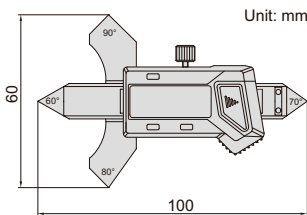

Unit: mm



4831-20A

- Buttons: zero, mm/inch, on/off
- Battery LR44
- Made of stainless steel

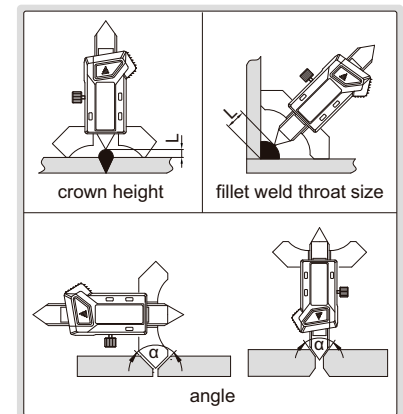

| Code | Measurement | Range | Resolution | Accuracy |
|----------|-------------------------|--------------------|----------------|----------|
| 4831-20A | crown height | 0-7mm | 0.01mm/0.0005" | ±0.03mm |
| | fillet weld throat size | 0-20mm | 0.01mm/0.0005" | ±0.1mm |
| | angle | 60°, 70°, 80°, 90° | — | ±1° |

FILLET WELDING GAGE

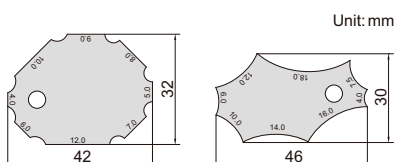

Unit: mm



4832-1

- Made of stainless steel
- Sizes marked on both faces

| Code | Throat size | Leg length | Accuracy |
|--------|----------------------------|---------------------------------|----------|
| 4832-1 | 4, 5, 6, 7, 8, 9, 10, 12mm | 4, 6, 7.5, 10, 12, 14, 16, 18mm | ±0.5mm |

