

DIAL INDICATOR STAND

- Vertical travel of holder: 250mm
- Fine adjustment range: entire stroke
- Supplied with dust cover

Code	Applicable holding stem	Anvil
6864-250	Ø8mm	serrated, flatness 1.5µm, hardness HRC60±2



6864-250

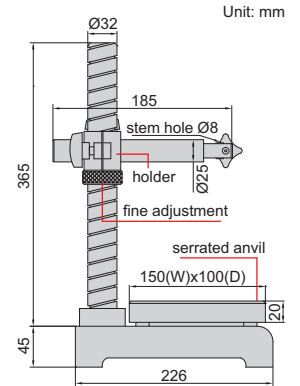

DIAL INDICATOR STANDS

- Vertical travel of holder: 100mm
- Fine adjustment range: 2mm
- Supplied with dust cover

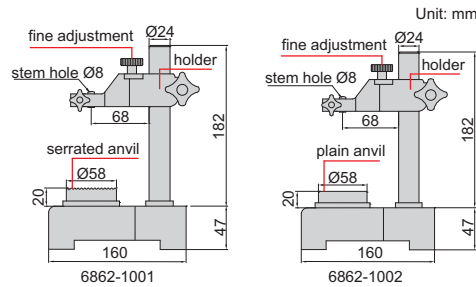

6862-1001

6862-1002

Code	Applicable holding stem	Anvil
6862-1001	Ø8mm	serrated, flatness 1.5µm, hardness HRC60±2
6862-1002	Ø8mm	plain, flatness 1.5µm, hardness HRC60±2

TRANSFER STAND

Application



Rigid construction, designed to make comparison height measurement (set zero with gage block then measure height of workpiece) with dial indicators or digital indicators (variation of measuring force is high)



6865-300

- Vertical travel of holder: 335mm
- Fine adjustment range: 2mm
- Supplied with dust cover

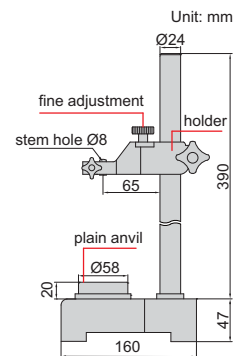

Code	Applicable holding stem	Anvil
6865-300	Ø8mm	plain, flatness 1.5µm, hardness HRC60±2